

CODE	Weight lbs/pc	Volume ft <sup>3</sup> /pc	ND	OD	S min	L1	L
12EICAL02	0.22	0.0111	2" IPS	2.370	0.220	2.64	3.43
12EICAL03	0.542	0.029	3" IPS	3.500	0.318	3.19	4.09
12EICAL04	1.129	0.055	4" IPS	4.500	0.409	3.54	4.69
12EICAL06	2.862	0.1534	6" IPS	6.625	0.602	4.73	6.04

**EloFIT**



ITEM: **EICAL**

DESC: END CAP  
SDR11

C:\Vault\_Temp\Disegn\Shede Tecniche\Elofit inches\Butt Fusion Fittings\EL10238.dwg



DRAWING No:

**EL10238**

SHEET OF REV.

1 3 -5

www.nupiamericas.com - info@nupiamericas.com

All dimensions have to be considered in inches with 5% tolerance if not otherwise mentioned excluding values as per standard ASTM D2513/D3261 and/or AWWA C901/C906

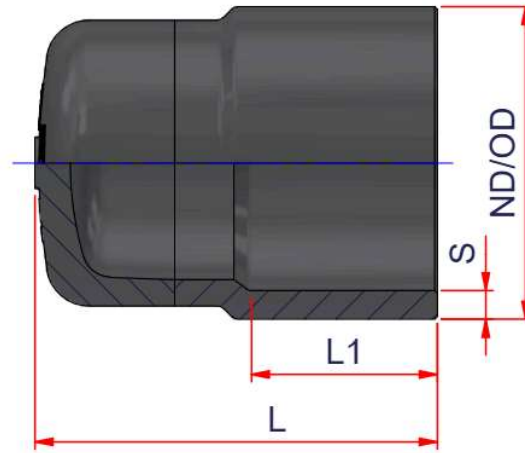

CODE	Weight lbs/pc	Volume ft <sup>3</sup> /pc	ND	OD	S min	L1	L
12EICAL08	7.189	0.576	8" IPS	8.625	0.784	7.40	13.38
12EICAL10	12.677	1.048	10" IPS	10.750	0.977	6.79	15.67

**EloFIT**



ITEM: **EICAL**

DESC: END CAP  
SDR11

C:\Vault\_Temp\Disegn\Shede Tecniche\Elofit inches\Butt Fusion Fittings\EL10238.dwg



DRAWING No:  
**EL10238**

SHEET OF	REV.
2 3	-5

www.nupiamericas.com - info@nupiamericas.com

All dimensions have to be considered in inches with 5% tolerance if not otherwise mentioned excluding values as per standard ASTM D2513/D3261 and/or AWWA C901/C906

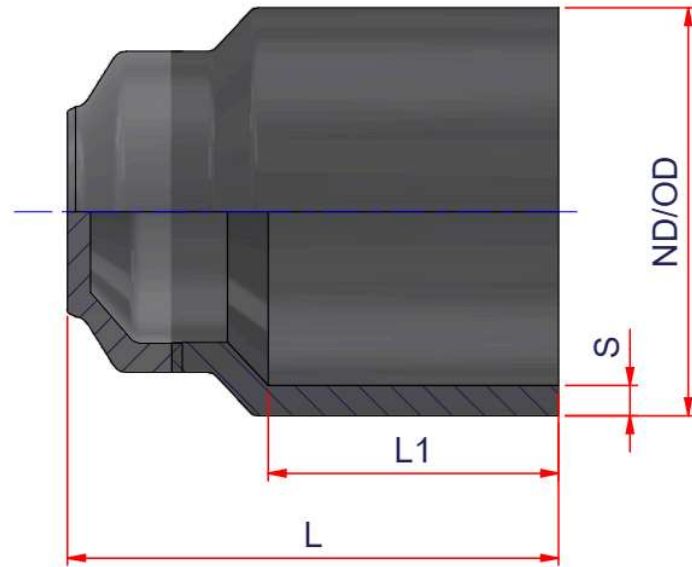

CODE	Weight lbs/pc	Volume ft <sup>3</sup> /pc	ND	OD	S min	L1	L
12EICAL12	-	1.6341	12" IPS	12.750	1.159	9.50	17.37
12EICAL14	-	2.0836	14" IPS	14.000	1.273	10.50	18.37
12EICAL16	-	2.9437	16" IPS	16.000	1.455	12.00	19.87

**EloFIT**



ITEM: **EICAL**

DESC: END CAP  
SDR11

C:\Vault\_Temp\Disegn\Schede Tecniche\Elofit inches\Butt Fusion Fittings\EL10238.dwg



DRAWING No:

**EL10238**

SHEET OF REV.

3 3 -5

www.nupiamericas.com - info@nupiamericas.com

All dimensions have to be considered in inches with 5% tolerance if not otherwise mentioned excluding values as per standard ASTM D2513/D3261 and/or AWWA C901/C906