

SPFC-D24T-5-230-2

CR45-1-1 DUAL SMART PUMP SYSTEM

INCLUDES THE FOLLOWING

- 1 ("D" Canister w/ 1 Outlet w/ 4" Male Inlet)
- 2 (CR45-1-1 Pump End)
- 2 (5HP Baldor Motor)
- 2 (5HP Yaskawa VFD (Single Phase 230V)
- 2 (3" Check and Butterfly Valve) (Field Installed before Pump End)
- 2 (Gauge Assembly w/ Transducer Sensor)

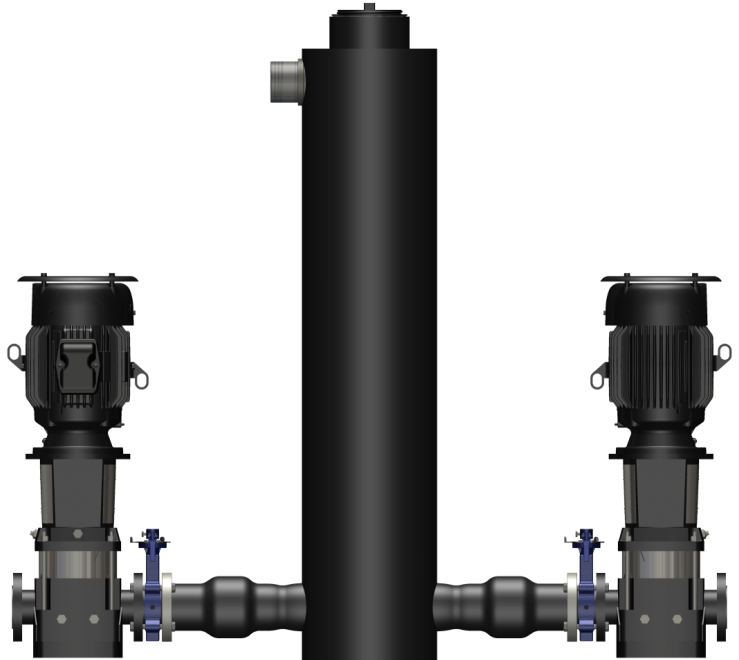

NOTE: Smart Pump image above is of actual product after field assembly.

Dimensional Data

NOTE: Smart Pump image below is shown without pumps for dimensional reference only.

